January 2020

QIAamp[®] Viral RNA Mini Handbook

For purification of viral RNA
from plasma, serum, cell-free
body fluids and culture
supernatants

Contents

Kit Contents	4
Storage	4
Intended Use	5
Safety Information	5
Quality Control	6
Introduction	7
Principle	7
Procedure	8
Cellular DNA contamination	10
Warnings and precautions	10
Sample volumes	11
Lysis	11
Carrier RNA	12
Addition of internal controls	12
Spin and vacuum procedures	13
Automated purification of RNA on QIAcube Instruments	13
Determination of yield	14
Equipment and Reagents to Be Supplied by User	15
Important Notes	16
Preparation of reagents	17
Handling of QIAamp Mini columns	20
Handling guidelines for the QIAvac 24 Plus	22

Centrifugation	26
Protocol: Purification of Viral RNA (Spin Protocol)	27
Protocol: Purification of Viral RNA (Vacuum Protocol)	31
Protocol: Sample Concentration	36
Protocol: Purification of Cellular, Bacterial or Viral DNA from Urine	37
Troubleshooting Guide	38
Appendix A: General Remarks on Handling RNA	41
Ordering Information	44
Document Revision History	47

Kit Contents

QIAamp Viral RNA Mini Kit	(50)	(250)
Catalog no.	52904	52906
No. of preps	50	250
QIAamp Mini Spin Columns	50	250
Collection Tubes (2 ml)	150	750
Buffer AVL*	31 ml	5 x 31 ml
Buffer AW1* (concentrate)	19 ml	98 ml
Buffer AW2† (concentrate)	13 ml	66 ml
Buffer AVE†	3 x 2 ml	10 x 2 ml
Carrier RNA (poly A)	310 µg	5 x 310 µg

* Contains chaotropic salt which is an irritant. Not compatible with disinfecting reagents that contain bleach. See page 5 for safety information.

† Contains sodium azide as a preservative.

Storage

QIAamp Mini spin columns should be stored dry at room temperature (15–25°C); storage at higher temperatures should be avoided. All solutions should be stored at room temperature unless otherwise stated. QIAamp Mini spin columns and all buffers and reagents can be stored under these conditions until the expiration date on the kit box without showing any reduction in performance.

Intended Use

The QIAamp Viral RNA Mini Kit is intended for molecular biology applications. This product is not intended for the diagnosis, prevention or treatment of a disease.

QIAcube® Connect is designed to perform fully automated purification of nucleic acids and proteins in molecular biology applications. The system is intended for use by professional users trained in molecular biological techniques and the operation of QIAcube Connect.

All due care and attention should be exercised in the handling of the products. We recommend all users of QIAGEN® products to adhere to the NIH guidelines that have been developed for recombinant DNA experiments or to other applicable guidelines.

Safety Information

When working with chemicals, always wear a suitable lab coat, disposable gloves and protective goggles. For more information, please consult the appropriate safety data sheets (SDSs). These are available online in convenient and compact PDF format at www.qiagen.com/safety where you can find, view and print the SDS for each QIAGEN kit and kit component.

CAUTION



DO NOT add bleach or acidic solutions directly to the sample preparation waste

Buffers AVL and AW1 contain guanidine salts, which can form highly reactive compounds when combined with bleach. If liquid containing these buffers is spilt, clean with a suitable laboratory detergent and water. If the spilt liquid contains potentially infectious agents, clean

the affected area first with laboratory detergent and water, and then with 1% (v/v) sodium hypochlorite.

Quality Control

In accordance with QIAGEN's ISO-certified Quality Management System, each lot of QIAamp Viral RNA Mini Kit is tested against predetermined specifications to ensure consistent product quality.

Introduction

Please take a few moments to read this handbook carefully before beginning your preparation. The “Important Notes”, on page 16, and the comments within the QIAamp Viral RNA Mini protocols, beginning on page 27, are particularly valuable.

Principle

QIAamp Viral RNA Mini Kits provide the fastest and easiest way to purify viral RNA for reliable use in amplification technologies. Viral RNA can be purified from plasma (treated with anticoagulants other than heparin), serum and other cell-free body fluids. Samples may be fresh or frozen, but if frozen, should not be thawed more than once. Repeated freeze–thawing of plasma samples will lead to reduced viral titers and should be avoided for optimal sensitivity. Cryoprecipitates accumulate when samples are subjected to repeated freeze–thaw cycles. This may lead to clogging of the QIAamp membrane when using the vacuum protocol.

QIAamp Viral RNA Mini Kits are for general use and can be used for isolation of viral RNA from a wide variety of viruses, but performance cannot be guaranteed for every virus.

Procedure

QIAamp Viral RNA Mini Kits represent a well-established technology for general-use viral RNA preparation. The kit combines the selective binding properties of a silica-based membrane with the speed of microspin or vacuum technology and is highly suited for simultaneous processing of multiple samples. QIAamp Viral RNA spin protocols can be fully automated on QIAcube Connect (see page 13). The sample is first lysed under highly denaturing conditions to inactivate RNases and to ensure isolation of intact viral RNA. Buffering conditions are then adjusted to provide optimum binding of the RNA to the QIAamp membrane, and the sample is loaded onto the QIAamp Mini spin column. The RNA binds to the membrane, and contaminants are efficiently washed away in two steps using two different wash buffers. High-quality RNA is eluted in a special RNase-free buffer, ready for direct use or safe storage. The purified RNA is free of protein, nucleases and other contaminants and inhibitors. The special QIAamp membrane guarantees extremely high recovery of pure, intact RNA in just 20 minutes without the use of phenol/chloroform extraction or alcohol precipitation.

Adsorption to the QIAamp membrane

The buffering conditions of the lysate must be adjusted to provide optimum binding conditions for the viral RNA before loading the sample onto the QIAamp Mini column. Viral RNA is adsorbed onto the QIAamp silica membrane during two brief centrifugation steps or by vacuum. Salt and pH conditions in the lysate ensure that protein and other contaminants, which can inhibit downstream enzymatic reactions, are not retained on the QIAamp membrane. If the initial sample volume is larger than 140 µl, it will be necessary to load the lysate onto the QIAamp Mini column in several steps.

QIAamp Viral RNA Mini Spin Procedure

Sample



QIAamp Viral RNA Mini Vacuum Procedure

Sample

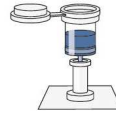

Vacuum

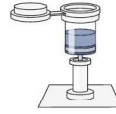

Vacuum

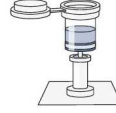

Vacuum



Lyse

Bind

Wash
(Buffer AW1)

Wash
(Buffer AW2)

Elute

Pure viral nucleic acid

Removal of residual contaminants

Viral RNA, bound to the QIAamp membrane, is washed free of contaminants during two short centrifugation or vacuum steps. The use of two different wash buffers, AW1 and AW2, significantly improves the purity of the eluted RNA. Optimized wash conditions ensure complete removal of any residual contaminants without affecting RNA binding.

Elution with Buffer AVE

Buffer AVE is RNase-free water that contains 0.04% sodium azide to prevent microbial growth and subsequent contamination with RNases. Sodium azide affects spectrophotometric absorbance readings between 220 and 280 nm but has no effect on downstream applications, such as RT-PCR. Should you wish to determine the purity of the eluted RNA, elution with RNase-free water instead of Buffer AVE is recommended.

Cellular DNA contamination

The QIAamp Viral RNA Mini Kit is not designed to separate viral RNA from cellular DNA, and both will be purified in parallel if present in the sample. To avoid co-purification of cellular DNA, the use of cell-free body fluids for preparation of viral RNA is recommended. Samples containing cells, such as cerebrospinal fluid, bone marrow, urine and most swabs, should first be filtered, or centrifuged for 10 minutes at 1500 x *g* and the supernatant used. If RNA and DNA have been isolated in parallel, the eluate can be DNase digested using RNase-free DNase, followed by heat treatment (15 min, 70°C) to inactivate the DNase.

Warnings and precautions

RNA is extremely sensitive to RNases and should always be prepared with due care. Hands and dust particles may carry bacteria and molds and are the most common sources of RNase contamination. Please read “Appendix A: General Remarks on Handling RNA” (page 41) before starting.

PCR should always be carried out using good laboratory practices. Accordingly, a PCR laboratory should always be divided into three areas: an area for preparation of reagents, an area for preparation of samples and an area for amplification and detection. Due to the high sensitivity of PCR, it is absolutely necessary that all reagents remain pure and uncontaminated, and should be monitored carefully and routinely. Contaminated reagents must be discarded.

Sample volumes

QIAamp Mini columns can bind RNA greater than 200 nucleotides in length. Actual yield will depend on sample size, sample storage and virus titer. The procedure is optimized for use with 140 μ l samples, but samples up to 280 μ l can be used. Small samples should be adjusted to 140 μ l with phosphate-buffered saline (PBS) before loading, and samples with a low viral titer should be concentrated to 140 μ l before processing. For samples larger than 140 μ l, the amount of lysis buffer and other reagents added to the sample before loading must be increased proportionally, but the amounts of Buffers AW1 and AW2 used in the wash steps usually do not need to be increased. If the initial sample volume is increased, application of the lysed sample to the QIAamp Mini column will require multiple loading steps. There is no danger of overloading the QIAamp Mini column, and the quality of the purified RNA will be unaffected. For volumes greater than 560 μ l, concentration of the sample is recommended. See "Protocol: Sample Concentration", page 36.

Lysis

The sample is first lysed under the highly denaturing conditions provided by Buffer AVL to inactivate RNases and to ensure isolation of intact viral RNA. Carrier RNA, added to Buffer AVL, improves the binding of viral RNA to the QIAamp membrane especially in the case of low-titer samples, and limits possible degradation of the viral RNA due to any residual RNase activity.

Carrier RNA

Carrier RNA serves two purposes. Firstly, it enhances binding of viral nucleic acids to the QIAamp Mini membrane, especially if there are very few target molecules in the sample. Secondly, the addition of large amounts of carrier RNA reduces the chance of viral RNA degradation in the rare event that RNase molecules escape denaturation by the chaotropic salts and detergent in Buffer AVL. If carrier RNA is not added to Buffer AVL this may lead to reduced viral RNA recovery.

The amount of lyophilized carrier RNA provided is sufficient for the volume of Buffer AVL supplied with the kit. The concentration of carrier RNA has been adjusted so that the QIAamp Viral RNA Mini Kit can be used as a generic purification system compatible with many different amplification systems and is suitable for a wide range of RNA viruses.

Different amplification systems vary in efficiency depending on the total amount of nucleic acid present in the reaction. Eluates from this kit contain both viral nucleic acids and carrier RNA, and amounts of carrier RNA will greatly exceed amounts of viral nucleic acids. Calculations of how much eluate to add to downstream amplifications should therefore be based on the amount of carrier RNA added. To obtain the highest levels of sensitivity in amplification reactions, it may be necessary to adjust the amount of carrier RNA added to Buffer AVL.

Addition of internal controls

Using the QIAamp Viral RNA Mini protocols in combination with commercially available amplification systems may require the introduction of an internal control into the purification procedure. Internal control RNA or DNA should be added together with the carrier RNA to the lysis buffer. For optimal purification efficiency, internal control molecules should be longer than 200 nucleotides, as smaller molecules are not efficiently recovered.

Refer to the manufacturer's instructions to determine the optimal concentration. Using a concentration other than that recommended may reduce amplification efficiency.

Spin and vacuum procedures

The QIAamp Viral RNA Mini purification procedure is carried out in three steps using QIAamp Mini columns in a standard microcentrifuge, on a vacuum manifold or on QIAcube Connect (see page 13). The procedures are designed to ensure that there is no sample-to-sample cross-contamination and allow safe handling of potentially infectious samples.

QIAamp Mini columns fit into most standard microcentrifuge tubes. In the spin protocol, due to the volume of filtrate, 2 ml collection tubes (provided) are required to support the QIAamp Mini column during loading and wash steps. For the vacuum protocol, a vacuum manifold (QIAvac 24 Plus or equivalent see page 18) and a vacuum pump capable of producing a vacuum of –800 to –900 mbar (e.g., Vacuum Pump) are required.

Eluted RNA can be collected in standard 1.5 ml microcentrifuge tubes (not provided). These tubes must be RNase-free to avoid degradation of viral RNA by RNases.

Automated purification of RNA on QIAcube Instruments

Purification of RNA can be fully automated on QIAcube Connect or the classic QIAcube. The innovative QIAcube instruments use advanced technology to process QIAGEN spin columns, enabling seamless integration of automated, low-throughput sample prep into your laboratory workflow. Sample preparation using QIAcube instruments follows the same steps as the manual procedure (i.e., lyse, bind, wash and elute), enabling you to continue using the QIAamp Viral RNA Mini Kit for purification of high-quality RNA.

QIAcube instruments are preinstalled with protocols for purification of plasmid DNA, genomic DNA, RNA, viral nucleic acids and proteins, plus DNA and RNA cleanup. The range of protocols available is continually expanding, and additional QIAGEN protocols can be downloaded free of charge at www.qiagen.com/qiacubeprotocols.



QIAcube Connect.

Determination of yield

Yields of viral RNA isolated from biological samples are normally less than 1 μg and therefore difficult to determine photometrically. Keep in mind that the carrier RNA (5.6 μg per 140 μl sample) will account for most of the RNA present. Quantitative RT-PCR is recommended for determination of viral RNA yield.

Determination of viral RNA length

The size distribution of viral RNA purified using QIAamp spin columns can be checked by denaturing agarose gel electrophoresis followed by hybridization with a virus-specific labeled probe and autoradiography (Sambrook, J. and Russell, D. W. [2001] *Molecular Cloning: A Laboratory Manual*, 3rd ed. Cold Spring Harbor, NY: Cold Spring Harbor Laboratory Press).

Equipment and Reagents to Be Supplied by User

When working with chemicals, always wear a suitable lab coat, disposable gloves and protective goggles. For more information, consult the appropriate safety data sheets (SDSs), available from the product supplier.

- Ethanol (96–100%)*
- 1.5 ml microcentrifuge tubes
- Sterile, RNase-free pipette tips (pipette tips with aerosol barriers for preventing cross-contamination are recommended)
- Microcentrifuge (with rotor for 1.5 ml and 2 ml tubes)

For vacuum protocols

- QIAvac 24 Plus vacuum manifold (cat. no. 19413) or equivalent
- VacConnectors (cat. no. 19407)
- Vacuum Regulator (cat. no. 19530) for easy monitoring of vacuum pressures and easy releasing of vacuum
- Vacuum Pump (cat. no. 84010 [USA and Canada], 84000 [Japan] or 84020 [rest of world]) or equivalent pump capable of producing a vacuum of –800 to –900 mbar
- **Optional:** VacValves (cat. no. 19408)
- **Optional:** QIAvac Connecting System (cat. no. 19419)

* Do not use denatured alcohol, which contains other substances, such as methanol or methylethylketone.

Important Notes

If preparing RNA for the first time, see “Appendix A: General Remarks on Handling RNA”, page 41. All steps of the QIAamp Viral RNA Mini protocols should be performed quickly and at room temperature (15–25°C).

After collection and centrifugation, plasma (untreated or treated with anticoagulants other than heparin) or serum can be stored at 2–8°C for up to 6 hours. For long-term storage, freezing at –30°C to –15°C or –90°C to –65°C in aliquots is recommended. Frozen plasma or serum samples must not be thawed more than once. Repeated freezing and thawing leads to denaturation and precipitation of proteins, causing reduced viral titers and subsequently reduced yields of the isolated viral RNA. In addition, cryoprecipitates formed by freeze–thawing will cause clogging of the QIAamp membrane. If cryoprecipitates are visible, they can be pelleted by briefly centrifuging at 6800 x g for 3 minutes. The cleared supernatant should be removed, without disturbing the pellet, and processed immediately. This step will not reduce viral titers.

The QIAamp Viral RNA Mini procedure is not designed to separate RNA from DNA. To avoid cellular DNA contamination follow the guidelines in “Cellular DNA contamination” on page 10.

The QIAamp Viral RNA Mini procedure isolates all RNA molecules larger than 200 nucleotides. Smaller RNA molecules will not bind quantitatively under the conditions used.

Preparation of reagents

Addition of carrier RNA to Buffer AVL*

Add 310 μ l Buffer AVE to the tube containing 310 μ g lyophilized carrier RNA to obtain a solution of 1 μ g/ μ l. Dissolve the carrier RNA thoroughly, divide it into conveniently sized aliquots, and store it at -30°C to -15°C . Do not freeze–thaw the aliquots of carrier RNA more than three times.

Check Buffer AVL for precipitate, and if necessary incubate at 80°C until the precipitate is dissolved. Calculate the volume of Buffer AVL–carrier RNA mix needed per batch of samples by selecting the number of samples to be simultaneously processed from Table 1 (next page). For larger numbers of samples, volumes can be calculated using the following sample calculation:

$$n \times 0.56 \text{ ml} = y \text{ ml}$$

$$y \text{ ml} \times 10 \mu\text{l/ml} = z \mu\text{l}$$

Where: **n** = number of samples to be processed simultaneously

y = calculated volume of Buffer AVL

z = volume of carrier RNA–Buffer AVE to add to Buffer AVL

Gently mix by inverting the tube 10 times. To avoid foaming, do not vortex.

* Contains chaotropic salt. Take appropriate laboratory safety measures and wear gloves when handling. Not compatible with disinfecting agents that contain bleach. See page 5 for safety information.

Table 1. Volumes of Buffer AVL and carrier RNA–Buffer AVE mix required for the QIAamp Viral RNA Mini procedure

No. samples	Buffer AVL (ml)	Carrier RNA–AVE (µl)	No. samples	Buffer AVL (ml)	Carrier RNA–AVE (µl)
1	0.56	5.6	13	7.28	72.8
2	1.12	11.2	14	7.84	78.4
3	1.68	16.8	15	8.4	84.0
4	2.24	22.4	16	8.96	89.6
5	2.80	28.0	17	9.52	95.2
6	3.36	33.6	18	10.08	100.8
7	3.92	39.2	19	10.64	106.4
8	4.48	44.8	20	11.20	112.0
9	5.04	50.4	21	11.76	117.6
10	5.60	56.0	22	12.32	123.2
11	6.16	61.6	23	12.88	128.8
12	6.72	67.2	24	13.44	134.4

Note: The sample-preparation procedure is optimized for 5.6 µg of carrier RNA per sample. If less carrier RNA has been shown to be better for your amplification system, transfer only the required amount of dissolved carrier RNA to the tubes containing Buffer AVL. (Use of less than 5.6 µg carrier RNA per sample must be validated for each particular sample type and downstream assay.)

Buffer AVL–carrier RNA should be prepared fresh, and is stable at 2–8°C for up to 48 hours. This solution develops a precipitate when stored at 2–8°C that must be redissolved by warming at 80°C before use. Do not warm Buffer AVL–carrier RNA solution more than six times. Do not incubate at 80°C for more than 5 minutes. Frequent warming and extended incubation will cause degradation of carrier RNA, leading to reduced recovery of viral RNA and eventually false negative RT-PCR results. This is particularly the case with low-titer samples.

Buffer AW1 *

Buffer AW1 is supplied as a concentrate. Before using for the first time, add the appropriate amount of ethanol (96–100%) as indicated on the bottle and in Table 2. Buffer AW1 is stable for 1 year when stored closed at room temperature (15–25°C), but only until the kit expiration date.

Table 2. Preparation of Buffer AW1

Kit cat. no.	No. preps	AW1 concentrate	Ethanol	Final volume
52904	50	19 ml	25 ml	44 ml
52904	250	98 ml	130 ml	228 ml

Buffer AW2 †

Buffer AW2 is supplied as a concentrate. Before using for the first time, add the appropriate amount of ethanol (96–100%) to Buffer AW2 concentrate as indicated on the bottle and in Table 3.

Buffer AW2 is stable for 1 year when stored closed at room temperature (15–25°C), but only until the kit expiration date.

Table 3. Preparation of Buffer AW2

Kit cat. no.	No. preps	AW2 concentrate	Ethanol	Final volume
52904	50	13 ml	30 ml	43 ml
52904	250	66 ml	160 ml	226 ml

* Contains chaotropic salt. Take appropriate laboratory safety measures and wear gloves when handling. Not compatible with disinfecting agents that contain bleach. See page 5 for safety information.

† Contains sodium azide as a preservative.

Handling of QIAamp Mini columns

Owing to the sensitivity of nucleic acid amplification technologies, the following precautions are necessary when handling QIAamp Mini columns to avoid cross-contamination between sample preparations:

- Carefully apply the sample or solution to the QIAamp Mini column. Pipet the sample into the QIAamp Mini column without wetting the rim of the column.
- Change pipette tips between all liquid transfer steps. The use of aerosol-barrier tips is recommended.
- Avoid touching the QIAamp membrane with the pipette tip.
- After all pulse-vortexing steps, briefly centrifuge 1.5 ml microcentrifuge tubes to remove drops from the inside of the lid.
- Wear gloves throughout the procedure. In case of contact between gloves and sample, change gloves immediately.

Spin protocol

- Close the QIAamp Mini column before placing it in the microcentrifuge. Centrifuge as described.
- Remove the QIAamp Mini column and collection tube from the microcentrifuge. Place the QIAamp Mini column in a new collection tube. Discard the filtrate and the old collection tube. Please note that the filtrate may contain hazardous waste and should be disposed of properly.
- Open only one QIAamp Mini column at a time, and take care to avoid generating aerosols.
- For efficient parallel processing of multiple samples, it is recommended to fill a rack with collection tubes to which the QIAamp Mini columns can be transferred after centrifugation. Used collection tubes containing the filtrate can be discarded, and the new collection tubes containing the QIAamp Mini columns can be placed directly in the microcentrifuge.

Vacuum protocol on the QIAvac 24 Plus

The QIAvac 24 Plus is designed for fast and efficient vacuum processing of up to 24 QIAGEN spin columns in parallel. Samples and wash solutions are drawn through the column membranes by vacuum instead of centrifugation, providing greater speed and reduced hands-on time in purification procedures.

In combination with the QIAvac Connecting System (optional), the QIAvac 24 Plus can be used as a flow-through system. The sample flow-through is collected in a separate waste bottle.

For maintenance of the QIAvac 24 Plus, please refer to the handling guidelines in the *QIAvac 24 Plus Handbook*.

Processing QIAamp Mini columns on the QIAvac 24 Plus

QIAamp Mini columns are processed on the QIAvac 24 Plus using VacConnectors and reusable VacValves. VacValves (optional) are inserted directly into the luer slots of the QIAvac 24 Plus manifold and ensure a steady flow rate, facilitating parallel processing of samples of different natures (e.g., plasma and serum), volumes or viscosities. They should be used if sample flow rates differ significantly to ensure consistent vacuum. VacConnectors are disposable connectors that fit between QIAamp Mini columns and VacValves or between QIAamp Mini columns and the QIAvac 24 Plus manifold. They prevent direct contact between the column and VacValve or QIAvac 24 Plus manifold during purification, thereby avoiding any cross-contamination between samples. VacConnectors are discarded after a single use.

Handling guidelines for the QIAvac 24 Plus

- Always place the QIAvac 24 Plus on a secure bench top or work area. If dropped, the QIAvac 24 Plus manifold may crack.
- Always store the QIAvac 24 Plus clean and dry. For cleaning procedures, see the *QIAvac 24 Plus Handbook*.
- The components of the QIAvac 24 Plus are not resistant to certain solvents (Table 4, next page). If these solvents are spilled on the unit, rinse it thoroughly with water.
- To ensure consistent performance, do not apply silicone or vacuum grease to any part of the QIAvac 24 Plus manifold.
- Always use caution and wear safety glasses when working near a vacuum manifold under pressure.
- Contact QIAGEN Technical Services or your local distributor for information concerning spare or replacement parts.
- The vacuum pressure is the pressure differential between the inside of the vacuum manifold and the atmosphere (standard atmospheric pressure 1013 millibar or 760 mm Hg) and can be measured using the QIAvac Connecting System or a vacuum regulator (Figure 1, next page). The vacuum protocol requires a vacuum pump capable of producing a vacuum of –800 to –900 mbar (e.g., QIAGEN's, Vacuum Pump). Higher vacuum pressures must be avoided. Use of vacuum pressures lower than recommended may reduce DNA yield and purity and increase the frequency of clogged membranes.

Table 4. Chemical resistance properties of the QIAvac 24 Plus

Resistant to:	Not resistant to:
Acetic acid	Benzene
Chromic acid	Chloroform
Chaotropic salts	Ethers
Chlorine bleach	Phenol
Hydrochloric acid	Toluene
SDS	-
Sodium chloride	-
Sodium hydroxide	-
Tween® 20	-
Urea	-



Figure 1. The Vacuum Regulator.

Setup of the QIAvac 24 Plus vacuum manifold

1. Connect the QIAvac 24 Plus to a vacuum source. If using the QIAvac Connecting System, connect the system to the manifold and vacuum source as described in Appendix A of the *QIAvac 24 Plus Handbook*.

Recommended: Insert a VacValve into each luer slot of the QIAvac 24 Plus that is to be used (Figure 2, next page).

VacValves should be used if flow rates of samples differ significantly to ensure consistent vacuum.

2. Insert a VacConnector into each VacValve (Figure 2) or directly into each luer slot of the QIAvac 24 Plus that is to be used. Close unused luer slots with luer plugs or close the inserted VacValve.

Perform this step directly before starting the purification to avoid exposure of VacConnectors to potential contaminants in the air.

3. Place the QIAamp Mini columns into the VacConnectors on the manifold (Figure 2).
4. For nucleic acid purification, follow the instructions in the vacuum protocol. Discard the VacConnectors appropriately after use.

Leave the lid of the QIAamp Mini column open while applying vacuum.

Switch off the vacuum between steps to ensure that a consistent, even vacuum is applied during processing. For faster vacuum release, a vacuum regulator should be used (Figure 1).

Note: Each VacValve can be closed individually when the sample is completely drawn through the spin column, allowing parallel processing of samples of different volumes or viscosities.

5. After processing samples, clean the QIAvac 24 Plus (see “Cleaning and Decontaminating the QIAvac 24 Plus” in the *QIAvac 24 Plus Handbook*).

Note: Buffers AVL and AW1 used in QIAamp Viral RNA Mini procedure are not compatible with disinfecting agents containing bleach. See page 5 for safety information.

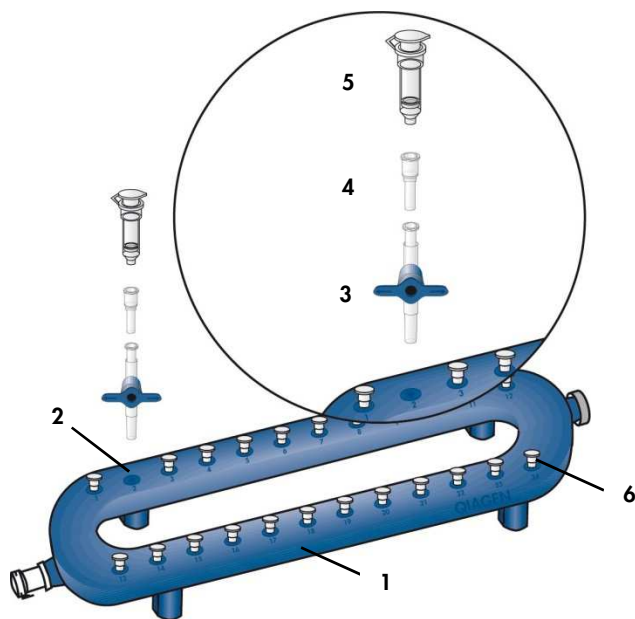

Figure 2. Setting up the QIAvac 24 Plus with QIAamp Mini columns using VacValves and VacConnectors. 1 = QIAvac 24 Plus vacuum manifold; 2 = Luer slot of the QIAvac 24 Plus; 3 = VacValve (optional; must be purchased separately); 4 = VacConnector (must be purchased separately); 5 = QIAamp column; 6 = Luer slot closed with luer plug.

Centrifugation

QIAamp Mini columns will fit into most standard 1.5 ml or 2 ml microcentrifuge tubes. Additional 2 ml collection tubes are available separately.

Centrifugation of QIAamp Mini columns is performed at 6000 x g (8000 rpm) to limit centrifuge noise. Centrifugation at full speed will not affect RNA yield. Centrifugation at lower speeds for lysate loading and the first wash step is also acceptable, provided that the complete solution is transferred through the membrane. At the second wash step centrifugation at full speed is strongly recommended.

All centrifugation steps are carried out at room temperature (15–25°C).

Protocol: Purification of Viral RNA (Spin Protocol)

This protocol is for purification of viral RNA from 140 µl plasma, serum, urine, cell-culture media or cell-free body fluids using a microcentrifuge. For automated purification of viral RNA using the QIAamp Viral RNA Mini Kit on QIAcube Connect, refer to the *QIAcube Connect User Manual* and the relevant protocol sheet.

Larger starting volumes, up to 560 µl (in multiples of 140 µl), can be processed by increasing the initial volumes proportionally and loading the QIAamp Mini column multiple times, as described below in the protocol. Some samples with very low viral titers should be concentrated before the purification procedure; see "Protocol: Sample Concentration" (page 36).

Alternatively, larger sample volumes can be processed using one of the following kits, which provide simultaneous purification of viral DNA and RNA:

- QIAamp MinElute® Spin Kit* – 200 µl
- QIAamp MinElute Vacuum Kit – 500 µl
- QIAamp UltraSens® Virus Kit – 1000 µl

Important points before starting

- Read "Important Notes" (page 16) before starting the protocol.
- All centrifugation steps are carried out at room temperature (15–25°C).

* Fully automatable on QIAcube Connect. See www.qiagen.com/qiacubeprotocols for protocols.

Things to do before starting

- Equilibrate samples to room temperature (15–25°C).
- Equilibrate Buffer AVE to room temperature for elution in step 11.
- Check that Buffer AW1 and Buffer AW2 have been prepared according to the instructions on page 19.
- Add carrier RNA reconstituted in Buffer AVE to Buffer AVL according to instructions on page 17.

Procedure

1. Pipet 560 µl prepared Buffer AVL containing carrier RNA into a 1.5 ml microcentrifuge tube.

Note: If the sample volume is larger than 140 µl, increase the amount of Buffer AVL–carrier RNA proportionally (e.g., a 280 µl sample will require 1120 µl Buffer AVL–carrier RNA) and use a larger tube.

2. Add 140 µl plasma, serum, urine, cell-culture supernatant or cell-free body fluid to the Buffer AVL–carrier RNA in the microcentrifuge tube. Mix by pulse-vortexing for 15 s.

Note: To ensure efficient lysis, it is essential that the sample is mixed thoroughly with Buffer AVL to yield a homogeneous solution. Frozen samples that have only been thawed once can also be used.

3. Incubate at room temperature (15–25°C) for 10 min.

Note: Viral particle lysis is complete after lysis for 10 min at room temperature. Longer incubation times have no effect on the yield or quality of the purified RNA.

4. Briefly centrifuge the tube to remove drops from the inside of the lid.

5. Add 560 μl ethanol (96–100%) to the sample, and mix by pulse-vortexing for 15 s. After mixing, briefly centrifuge the tube to remove drops from inside the lid.

Note: Use only ethanol, since other alcohols may result in reduced RNA yield and purity. Do not use denatured alcohol, which contains other substances, such as methanol or methylethylketone. If the sample volume is greater than 140 μl , increase the amount of ethanol proportionally (e.g., a 280 μl sample will require 1 120 μl ethanol). To ensure efficient binding, it is essential that the sample is mixed thoroughly with the ethanol to yield a homogeneous solution.

6. Carefully apply 630 μl of the solution from step 5 to the QIAamp Mini column (in a 2 ml collection tube) without wetting the rim. Close the cap, and centrifuge at 6000 $\times g$ (8000 rpm) for 1 min. Place the QIAamp Mini column into a clean 2 ml collection tube, and discard the tube containing the filtrate.

Note: Close each spin column to avoid cross-contamination during centrifugation.

Note: Centrifugation is performed at 6000 $\times g$ (8000 rpm) to limit microcentrifuge noise. Centrifugation at full speed will not affect the yield or purity of the viral RNA. If the solution has not completely passed through the membrane, centrifuge again at a higher speed until all of the solution has passed through.

7. Carefully open the QIAamp Mini column, and repeat step 6. If the sample volume was greater than 140 μl , repeat this step until all of the lysate has been loaded onto the spin column.

8. Carefully open the QIAamp Mini column, and add 500 μl Buffer AW1. Close the cap, and centrifuge at 6000 $\times g$ (8000 rpm) for 1 min. Place the QIAamp Mini column in a clean 2 ml collection tube (provided), and discard the tube containing the filtrate.

Note: It is not necessary to increase the volume of Buffer AW1 even if the original sample volume was larger than 140 μl .

-
9. Carefully open the QIAamp Mini column, and add 500 μ l Buffer AW2. Close the cap and centrifuge at full speed (20,000 \times g; 14,000 rpm) for 3 min. Continue directly with step 11, or to eliminate possible Buffer AW2 carryover, perform step 10 and then continue with step 11.

Note: Residual Buffer AW2 in the eluate may cause problems in downstream applications. Some centrifuge rotors may vibrate upon deceleration, resulting in flow-through, containing Buffer AW2, contacting the QIAamp Mini column.

Removing the QIAamp Mini column and collection tube from the rotor may also cause flow-through to come into contact with the QIAamp Mini column. In these cases, the optional step 10 should be performed.

Recommended: Place the QIAamp Mini column in a new 2 ml collection tube (not provided), and discard the old collection tube with the filtrate. Centrifuge at full speed for 1 min.

10. Place the QIAamp Mini column in a clean 1.5 ml microcentrifuge tube (not provided). Discard the old collection tube containing the filtrate. Carefully open the QIAamp Mini column and add 60 μ l Buffer AVE equilibrated to room temperature. Close the cap, and incubate at room temperature for 1 min.
11. Centrifuge at 6000 \times g (8000 rpm) for 1 min.

A single elution with 60 μ l Buffer AVE is sufficient to elute at least 90% of the viral RNA from the QIAamp Mini column. Performing a double elution using 2 \times 40 μ l Buffer AVE will increase yield by up to 10%. Elution with volumes of less than 30 μ l will lead to reduced yields and will not increase the final concentration of RNA in the eluate.

Viral RNA is stable for up to one year when stored at -30°C to -15°C or at -90°C to -65°C .

Protocol: Purification of Viral RNA (Vacuum Protocol)

This protocol is for purification of viral RNA from 140 µl plasma, serum, urine, cell-culture media or cell-free body fluids using the QIAvac 24 Plus or equivalent vacuum manifold. Larger starting volumes, up to 560 µl (in multiples of 140 µl), can be processed by increasing the initial volumes proportionally and loading the QIAamp Mini spin column multiple times, as described below in the protocol. Some samples with very low viral titers should be concentrated before the purification procedure; see “Protocol: Sample Concentration” (page 36).

Alternatively, larger sample volumes can be processed using one of the following kits, which provide simultaneous purification of viral DNA and RNA:

- QIAamp MinElute Spin Kit* – 200 µl
- QIAamp MinElute Vacuum Kit – 500 µl
- QIAamp UltraSens Virus Kit – 1000 µl

Important points before starting

- Read “Important Notes” (page 16) before starting the protocol.
- All centrifugation steps are carried out at room temperature (15–25°C).

* Fully automatable on QIAcube Connect. See www.qiagen.com/qiacubeprotocols for protocols.

Things to do before starting

- Equilibrate samples to room temperature (15–25°C).
- Equilibrate Buffer AVE to room temperature for elution in step 10.
- Check that Buffer AW1 and Buffer AW2 have been prepared according to the instructions on page 19.
- Add carrier RNA reconstituted in Buffer AVE to Buffer AVL according to instructions on page 17.
- For processing using VacConnectors and VacValves, set up the QIAvac 24 Plus, as described on page 24.

Procedure

1. Pipet 560 µl prepared Buffer AVL containing carrier RNA into a 1.5 ml microcentrifuge tube.

If the sample volume is larger than 140 µl, increase the amount of Buffer AVL–carrier RNA proportionally (e.g., a 280 µl sample will require 1120 µl Buffer AVL–carrier RNA) and use a larger tube.

2. Add 140 µl plasma, serum, urine, cell-culture supernatant or cell-free body fluid to the Buffer AVL–carrier RNA in the microcentrifuge tube. Mix by pulse-vortexing for 15 s.
To ensure efficient lysis, it is essential that the sample is mixed thoroughly with Buffer AVL to yield a homogeneous solution. Frozen samples that have only been thawed once can also be used.
3. Incubate at room temperature (15–25°C) for 10 min.
Viral particle lysis is complete after lysis for 10 min at room temperature. Longer incubation times have no effect on the yield or quality of the purified RNA.
4. Briefly centrifuge the tube to remove drops from the inside of the lid.

-
5. Add 560 μl ethanol (96–100%) to the sample, and mix by pulse-vortexing for 15 s. After mixing, briefly centrifuge the tube to remove drops from inside the lid.

Insert a QIAamp Mini column into the VacConnector on the QIAvac 24 Plus vacuum manifold.

Use only ethanol, since other alcohols may result in reduced yield and purity of the RNA. Do not use denatured alcohol, which contains other substances, such as methanol or methylethylketone. If the sample volume is greater than 140 μl , increase the amount of ethanol proportionally (e.g., a 280 μl sample will require 1 120 μl ethanol). To ensure efficient binding, it is essential that the sample is mixed thoroughly with the ethanol to yield a homogeneous solution.

The collection tube from the blister pack can be saved for the centrifugation in step 14.

6. Make sure that the main vacuum valve (between the vacuum pump and the vacuum manifold) and the screw cap valve (on the end of the QIAvac 24 Plus vacuum manifold) are closed. Switch on the vacuum pump by pressing the power switch.

The vacuum is applied only to the connecting system (if used) and not to the vacuum manifold.

Note: For fast and convenient release of the vacuum pressure, the QIAvac Connecting System or the Vacuum Regulator should be used.

7. Carefully apply 630 μl of the lysate from step 5 into the QIAamp Mini column without wetting the rim. Avoid touching the QIAamp Mini column membrane with the pipette tip.

-
8. Open the main vacuum valve. Be sure to leave the lid of the QIAamp Mini column open while applying vacuum. After all lysates have been drawn through the QIAamp Mini column, close the main vacuum valve and open the screw cap valve to vent the manifold. Close the screw cap valve after the vacuum is released from the manifold.

After closing the main vacuum valve, the vacuum is applied only to the connecting system (if used) and not the vacuum manifold.

Note: If the lysates from individual samples have not completely passed through the membrane despite the VacValves of all other QIAamp Mini columns being closed, place the QIAamp Mini column into a clean 2 ml collection tube (not provided), close the cap, and centrifuge at full speed for 3 min or until it has completely passed through. Continue with step 7 of the spin protocol (page 27). Additional collection tubes can be purchased separately.

Centrifugation is performed at 6000 x g (8000 rpm) to limit microcentrifuge noise.

Centrifugation at full speed will not affect the yield or purity of viral RNA.

9. Repeat steps 7 and 8.

If the sample volume was greater than 140 µl, repeat these steps until all of the lysate has been drawn through the QIAamp Mini column.

10. Apply 750 µl Buffer AW1 to the QIAamp Mini column without wetting the rim.

Avoid touching the QIAamp Mini column membrane with the pipette tip.

It is not necessary to increase the volume of Buffer AW1 even if the original sample volume was larger than 140 µl.

11. Open the main vacuum valve. After all Buffer AW1 has been drawn through the QIAamp Mini column, close the main vacuum valve and open the screw cap valve to vent the manifold. Close the screw cap valve after the vacuum is released from the manifold.

12. Apply 750 µl Buffer AW2 to the QIAamp Mini column without wetting the rim. Avoid touching the QIAamp Mini column membrane with the pipette tip. Leave the lid of the column open.

-
13. Open the main vacuum valve. After all Buffer AW2 has been drawn through the QIAamp Mini column, close the main vacuum valve and open the screw cap valve to vent the manifold. Close the screw cap valve after the vacuum is released from the manifold.
 14. Close the lid of the QIAamp Mini column. Remove it from the vacuum manifold and discard the VacConnector. Place the QIAamp Mini spin column in a clean 2 ml collection tube saved from step 5, and centrifuge at full speed for 1 min to dry the membrane completely.
 15. Place the QIAamp Mini spin column into a clean 1.5 ml microcentrifuge tube (not provided). Discard the collection tube containing the filtrate. Carefully open the QIAamp Mini spin column. Add 60 μ l Buffer AVE equilibrated to room temperature. Close the cap, and incubate at room temperature for 1 min. Centrifuge at 6000 \times g (8000 rpm) for 1 min.

A single elution with 60 μ l Buffer AVE is sufficient to elute at least 90% of the viral RNA from the QIAamp Mini spin column. Performing a double elution using 2 \times 40 μ l Buffer AVE will increase yield by up to 10%. Elution with volumes of less than 30 μ l will lead to reduced yields and will not increase the final concentration of RNA in the eluate.

Viral RNA is stable for up to one year when stored at -30°C to -15°C or at -90°C to -65°C .

Protocol: Sample Concentration

Plasma, serum, urine, cerebrospinal fluid, bone marrow and other body fluids often have very low viral titers. In these cases, concentrating samples of up to 3.5 ml to a final volume of 140 μ l is recommended.

Important point before starting

- Use centrifugal microconcentrators, such as Centricon® 100 (Amicon: 2 ml, cat. no. 4211), Microsep 100 (Filtron: 3.5 ml, cat. no. OD100C40), Ultrafree® CL (Millipore: 2 ml, cat. no. UFC4 THK 25) or equivalent from other suppliers.

Procedure

- Apply up to 3.5 ml sample to the microconcentrator, following the manufacturer's instructions.
- Centrifuge according to manufacturer's instructions to a final volume of 140 μ l.
- Some samples, plasma in particular, may be difficult to concentrate to 140 μ l due to high viscosity. Centrifugation for up to 6 hours may be necessary.
- Pipet 140 μ l concentrated sample into a 1.5 ml microcentrifuge tube and follow "Protocol: Purification of Viral RNA (Spin Protocol)", page 27.

Protocol: Purification of Cellular, Bacterial or Viral DNA from Urine

Buffer AVL, used in the QIAamp Viral RNA Mini procedure, inactivates the numerous unidentified PCR inhibitors found in urine. For isolation of cellular, bacterial or viral DNA from urine for use in PCR, "Protocol: Purification of Viral RNA (Spin Protocol)", page 27, is recommended.

Urine often contains very low numbers of cells, bacteria or viruses. In these cases, we recommend concentrating samples of up to 3.5 ml to a final volume of 140 μ l, as described below, before processing.

For purification of DNA from Gram-positive bacteria, please contact QIAGEN Technical Services.

Important point before starting

- Use centrifugal microconcentrators, such as Centricon-100 (Amicon: 2 ml, cat. no. 4211), Microsep 100 (Filtron: 3.5 ml, cat. no. OD100C40), Ultrafree-CL (Millipore: 2 ml, cat. no. UFC4 THK 25) or equivalent from other suppliers.

Procedure

1. Apply up to 3.5 ml of sample to the microconcentrator following the manufacturer's instructions.
2. Centrifuge according to manufacturer's instructions to a final volume of 140 μ l.
Some samples, plasma in particular, may be difficult to concentrate to 140 μ l due to high viscosity. Centrifugation for up to 6 hours may be necessary.
3. Pipet 140 μ l concentrated sample into a 1.5 ml microcentrifuge tube and follow Protocol: Purification of Viral RNA (Spin Protocol) on page 27.

Troubleshooting Guide

This troubleshooting guide may be helpful in solving any problems that may arise. For more information, see also the Frequently Asked Questions page at our Technical Support Center: www.qiagen.com/FAQ/FAQList.aspx. The scientists in QIAGEN Technical Services are always happy to answer any questions you may have about either the information and/or protocols in this handbook or sample and assay technologies (for contact information, visit www.qiagen.com).

Comments and suggestions

Little or no RNA in the eluate

- | | |
|---|--|
| a) Carrier RNA not added to Buffer AVL | Reconstitute carrier RNA in Buffer AVE and mix with Buffer AVL as described on page 17. Repeat the purification procedure with new samples. |
| b) Degraded carrier RNA | Carrier RNA reconstituted in Buffer AVE was not stored at -30°C to -15°C or underwent multiple freeze–thaw cycles. Alternatively, Buffer AVL–carrier RNA mixture was stored for more than 48 hours at $2-8^{\circ}\text{C}$. Prepare a new tube of carrier RNA dissolved in Buffer AVE and mix with Buffer AVL. Repeat the purification procedure with new samples. |
| c) Sample frozen and thawed more than once | Repeated freezing and thawing should be avoided. Always use fresh samples or samples thawed only once. |
| d) Low concentration of virus in the sample | Concentrate the sample volume to 140 μl using a microconcentrator. Repeat the RNA purification procedure with a new sample. See “Protocol: Sample Concentration” on page 36. |
| e) Inefficient protein denaturation in Buffer AVL | Precipitate, formed in Buffer AVL–carrier RNA after storage at $2-8^{\circ}\text{C}$, was not redissolved by heating before starting the procedure. Redissolve the precipitate and repeat the procedure with a new sample. |
| f) Buffer AVL prepared incorrectly | Check Buffer AVL for precipitate. Dissolve precipitate by incubation at 80°C . |
| g) No ethanol added to the lysate (step 5) | Repeat the purification procedure with a new sample. |
| h) Low percentage ethanol used | Repeat the purification procedure with a new sample. Use 96–100% ethanol in step 5. Do not use denatured alcohol, which contains other substances, such as methanol or methylethylketone. |

Comments and suggestions

- | | |
|--|---|
| i) Isopropanol used instead of ethanol | We recommend the use of ethanol as isopropanol causes reduced yields. |
| j) RNA degraded | Often RNA is degraded by RNases in the starting material (plasma, serum, body fluids). Ensure that the samples are processed quickly. If necessary, add RNase inhibitor to the sample. Check for RNase contamination of buffers and water, and ensure that no RNase is introduced during the procedure. |
| k) RNase contamination in Buffer AVE | Discard contaminated Buffer AVE. Repeat the purification procedure with a new sample and a fresh tube of Buffer AVE. Additional Buffer AVE is available separately. |
| l) Buffer AW1 or AW2 prepared incorrectly | Check that Buffer AW1 and AW2 concentrates were diluted with correct volumes of pure (96–100%) ethanol. Do not use denatured alcohol, which contains other substances, such as methanol or methylethylketone. Repeat the purification procedure with a new sample. |
| m) Buffer AW1 or AW2 prepared with 70% ethanol | Check that Buffer AW1 and AW2 concentrates were diluted with 96–100% ethanol. Repeat the purification procedure with a new sample. |
| n) Buffers AW1 and AW2 used in the wrong order | Ensure that Buffer AW1 and Buffer AW2 are used in used in the correct order in the protocol. Repeat the purification procedure with a new sample. |

RNA does not perform well in subsequent enzymatic reactions

- | | |
|--|---|
| a) Little or no RNA in the eluate | Check "Little or no RNA in the eluate," above, for possible reasons. |
| b) Inefficient virus lysis in Buffer AVL | Precipitate formed in Buffer AVL–carrier RNA due to temperature change before start of process. Repeat the procedure with new samples, and ensure that no precipitate has formed in Buffer AVL–carrier RNA at the beginning of the process. |
| c) Buffer AVL prepared incorrectly | Ensure that carrier RNA has been reconstituted in Buffer AVE and added to Buffer AVL (see page 17). |
| d) Too much carrier RNA in the eluate | Determine the maximum amount of carrier RNA suitable for your RT-PCR. Adjust the concentration of carrier RNA added to Buffer AVL accordingly. |
| e) Reduced sensitivity | Determine the maximum volume of eluate suitable for your RT-PCR. Reduce the volume of eluate added to the RT-PCR. |
| f) Buffers AW1 and AW2 used in the wrong order | Ensure that Buffer AW1 and Buffer AW2 are used in used in the correct order in the protocol. Repeat the purification procedure with a new sample. |
| g) New combination of reverse transcriptase and <i>Taq</i> DNA polymerase used | If enzymes are changed, it may be necessary to readjust the amount of carrier RNA solution added to Buffer AVL. |

Comments and suggestions

DNA contamination

DNA and RNA present in the sample

To avoid co-purification of DNA, use of cell-free body fluids for preparation of viral RNA is recommended. Samples containing cells, such as cerebrospinal fluid, bone marrow, urine and most swabs, should be made cell-free by centrifugation or filtration. If using centrifugation, pellet the cells for 10 min at 1500 x g and use supernatant for isolation of viral RNA. If DNA-free RNA is required, digest either the sample or the eluate with RNase-free DNase. DNase in the eluate must be inactivated by heat treatment (15 min, 70°C).

General handling

a) Lysate not completely passed through the membrane

Using the spin protocol: Centrifuge for 1 min at full speed or until all the lysate has passed through the membrane.

Using the vacuum protocol: Insufficient vacuum was applied or the lid of the spin column was closed during the vacuum step. Increase the vacuum, and open the lid while applying the vacuum. If the vacuum pressure cannot be increased, place the QIAamp Mini column in a clean 2 ml collection tube, close the cap, and centrifuge at 6000 x g (8000 rpm) for 3 min or until the lysate has completely passed through the membrane. Place the QIAamp Mini column into another clean 2 ml collection tube, and discard the tube containing the filtrate. Continue with step 7 of the spin protocol on page 27.

b) Clogged membrane

Cryoprecipitates have formed in plasma due to repeated freezing and thawing. Do not use plasma that has been frozen and thawed more than once.

c) Cross-contamination between samples

To avoid cross-contamination when handling QIAamp Mini spin columns, follow the guidelines in "Handling of QIAamp Mini columns" on page 20. Repeat the purification procedure with new samples.

d) Vacuum pressure too high/low

Using a vacuum pressure that is too high may damage the QIAamp membrane. Using too low a vacuum pressure may cause reduced RNA yield and purity. Use a vacuum regulator to adjust the pressure to -800 to -900 mbar for all vacuum steps.

Appendix A: General Remarks on Handling RNA

Handling RNA

Ribonucleases (RNases) are very stable and active enzymes that generally do not require cofactors to function. Since RNases are difficult to inactivate and even minute amounts are sufficient to destroy RNA, do not use any plasticware or glassware without first eliminating possible RNase contamination. Great care should be taken to avoid inadvertently introducing RNases into the RNA sample during or after the purification procedure. To create and maintain an RNase-free environment, the following precautions must be taken during pretreatment and use of disposable and nondisposable vessels and solutions while working with RNA.

General handling

Proper microbiological, aseptic technique should always be used when working with RNA. Hands and dust particles may carry bacteria and molds and are the most common sources of RNase contamination. Always wear latex or vinyl gloves while handling reagents and RNA samples to prevent RNase contamination from the surface of the skin or from dusty laboratory equipment. Change gloves frequently and keep tubes closed whenever possible. Keep purified RNA on ice when aliquots are pipetted for downstream applications.

Disposable plasticware

The use of sterile, disposable polypropylene tubes is recommended throughout the procedure. These tubes are generally RNase-free and do not require pretreatment to inactivate RNases.

Nondisposable plasticware

Nondisposable plasticware should be treated before use to ensure that it is RNase-free. Plasticware should be thoroughly rinsed with 0.1 M NaOH, 1 mM EDTA* followed by RNase-free water (see "Solutions", page 43). Alternatively, chloroform-resistant plasticware can be rinsed with chloroform* to inactivate RNases.

Glassware

Glassware should be treated before use to ensure that it is RNase-free. Glassware used for RNA work should be cleaned with a detergent,* thoroughly rinsed, and oven baked at 240°C for at least 4 hours (overnight, if more convenient) before use. Autoclaving alone will not fully inactivate many RNases. Alternatively, glassware can be treated with DEPC* (diethyl pyrocarbonate). Fill glassware with 0.1% DEPC (0.1% in water), allow to stand overnight (12 hours) at 37°C and then autoclave or heat to 100°C for 15 minutes to eliminate residual DEPC.

Note: Corex® tubes should be rendered RNase-free by treatment with DEPC and not by baking. This will reduce the failure rate of this type of tube during centrifugation.

Electrophoresis tanks

Electrophoresis tanks should be cleaned with detergent solution (e.g. 0.5% SDS),* rinsed with water, dried with ethanol,*† and then filled with a solution of 3% H₂O₂.* After 10 minutes at room temperature (15–25°C), the electrophoresis tanks should be rinsed thoroughly with RNase-free water.

* When working with chemicals, always wear a suitable lab coat, disposable gloves and protective goggles. For more information, consult the appropriate safety data sheets (SDSs), available from the product supplier.

† Plastics used for some electrophoresis tanks are not resistant to ethanol. Take proper care and check the supplier's instructions.

Solutions

Solutions (water and other solutions) should be treated with 0.1% DEPC. DEPC is a strong, but not absolute, inhibitor of RNases. It is commonly used at a concentration of 0.1% to inactivate RNases on glass or plasticware or to create RNase-free solutions and water. DEPC inactivates RNases by covalent modification. Add 0.1 ml DEPC to 100 ml of the solution to be treated and shake vigorously to bring the DEPC into solution. Let the solution incubate for 12 hours at 37°C. Autoclave for 15 minutes to remove any trace of DEPC. DEPC will react with primary amines and cannot be used directly to treat Tris* buffers. DEPC is highly unstable in the presence of Tris buffers and decomposes rapidly into ethanol and CO₂. When preparing Tris buffers, treat water with DEPC first, and then dissolve Tris to make the appropriate buffer. Trace amounts of DEPC will modify purine residues in RNA by carbethoxylation. Carbethoxylated RNA is translated with very low efficiency in cell-free systems. However, its ability to form DNA:RNA or RNA:RNA hybrids is not seriously affected unless a large fraction of the purine residues has been modified. Residual DEPC must always be eliminated from solutions or vessels by autoclaving or heating to 100°C for 15 minutes.

Note: QIAamp Viral RNA buffers are not rendered RNase-free by DEPC treatment and are therefore free of any DEPC contamination.

* When working with chemicals, always wear a suitable lab coat, disposable gloves and protective goggles. For more information, consult the appropriate safety data sheets (SDSs), available from the product supplier.

Ordering Information

Product	Contents	Cat. no.
QIAamp Viral RNA Mini Kit (50)	For 50 minipreps: 50 QIAamp Mini Spin Columns, Carrier RNA, Buffers and Collection Tubes (2 ml)	52904
QIAamp Viral RNA Mini Kit (250)	For 250 minipreps: 250 QIAamp Mini Spin Columns, Carrier RNA, Buffers and Collection Tubes (2 ml)	52906
QIAcube Connect and QIAcube Connect accessories – for fully automated sample preparation using QIAGEN spin-column kits		
QIAcube Connect*	Instrument, connectivity package, 1-year warranty on parts and labor	Inquire
Starter Pack, QIAcube	Filter-tips, 200 µl (1024), 1000 µl filter-tips (1024), 30 ml reagent bottles (12), rotor adapters (240), elution tubes (240), rotor adapter holder	990395
Filter-Tips, 1000 µl (1024)	Sterile, Disposable Filter-Tips (racked)	990352
Rotor Adapters (10 x 24)	For 240 preps: 240 Disposable Rotor Adapters; for use with QIAcube Connect	990394
QIAamp Viral RNA Mini Accessory Set	Additional Buffers and Reagents; for use with at least 11 x QIAamp Viral RNA Mini Kits (50; cat. no. 52904) or 5 x QIAamp Viral RNA Mini Kits (250; cat. no. 52906) on QIAcube Connect	1048147

Product	Contents	Cat. no.
Related products		
QIAamp MinElute Virus Spin Kit (50) [†]	For 50 minipreps: 50 QIAamp MinElute Columns, QIAGEN Protease, Carrier RNA, Buffers, Collection Tubes (2 ml)	57704
QIAamp MinElute Virus Vacuum Kit (50)	For 50 minipreps: 50 QIAamp MinElute Columns, QIAGEN Protease, Carrier RNA, Buffers, Extension Tubes (3 ml), Collection Tubes (1.5 ml)	57714
QIAamp MinElute Media Kit	For 50 minipreps: 50 QIAamp MinElute Columns, QIAGEN Proteinase K, Carrier RNA, Buffers, Extension Tubes (3 ml), Collection Tubes (1.5 ml)	57414
QIAamp Media MDx Kit (12)	For 12 x 96 preps: 12 QIAamp 96 Plates, Buffers, Proteinase K, S-Blocks, Disposable Troughs, Racks with Elution Microtubes CL (0.4 ml), Carrier RNA, Top Elute Fluid, Caps, Tape Pad	965752
QIAamp Virus BioRobot MDx Kit (12)	For 12 x 96 preps: 12 QIAamp 96 Plates, RNase-free Buffers, [§] QIAGEN Protease, Elution Microtubes CL, Caps, S-Blocks, Carrier RNA	965652
EZ1 [®] Virus Mini Kit v2.0 (48)	For 48 preps: Reagent Cartridges (Virus Mini v2.0), Disposable Filter-Tips, Disposable Tip-Holders, Sample Tubes (2 ml), Elution Tubes (1.5 ml), Buffer AVE, Carrier RNA	955134
EZ1 Virus Card v2.0	Preprogrammed card for EZ1 Virus v2.0 protocols	9017330

Product	Contents	Cat. no.
MagAttract® Virus Mini M48 Kit (192)	For 192 virus nucleic acid preps: MagAttract Suspension B and RNase-free reagents and buffers	955336
App. Package, M48, Infectious Disease	Software protocol package for infectious disease applications, v. 2.0, on the BioRobot M48 workstation	9016145
QIAamp RNA Blood Mini Kit (50)	For 50 RNA preps: 50 QIAamp Mini Spin Columns, 50 QIAshredder Spin Columns, Collection Tubes (1.5 ml and 2 ml), RNase-free Reagents and Buffers	52304
QIAamp DNA Blood Mini Kit (50) ^{††}	For 50 minipreps: 50 QIAamp Mini Spin Columns, QIAGEN Protease, Reagents, Buffers and Collection Tubes (2 ml)	51104
QIAamp 96 DNA Blood Kit (4) ^{††}	For 4 x 96 preps: 4 QIAamp 96 Plates, QIAGEN Protease, Reagents, Buffers, Lysis Plates and Collection Vessels	51161
QIAamp DNA Mini Kit (50) ^{††}	For 50 minipreps: 50 QIAamp Mini Spin Columns, Proteinase K, Reagents, Buffers and Collection Tubes (2 ml)	51304
Accessories		
Buffer AW1 (concentrate, 242 ml)	242 ml Wash Buffer (1) Concentrate for 1000 spin, 250 midi or 100 maxi preps	19081
Buffer AW2 (concentrate, 324 ml)	324 ml Wash Buffer (2) Concentrate	19072
Buffer AVL (155 ml)	For 250 preps: 155 ml Viral Lysis Buffer, 5 x 310 µg Carrier RNA	19073
Buffer AVE (108 x 2 ml)	108 x 2 ml Buffer AVE	1020953

Product	Contents	Cat. no.
Carrier RNA(poly A) 12x1350µg-15-25°C,KG	Carrier RNA (poly A) 12 x 1350 µg, 15–25°C, KG	1017647
Collection Tubes (2 ml)	1000 Collection Tubes (2 ml)	19201

* All QIAcube Connect instruments are provided with a region-specific connectivity package, including tablet and equipment necessary to connect to the local network. Further, QIAGEN offers comprehensive instrument service products, including service agreements, installation, introductory training and preventive subscription. Contact your local sales representative to learn about your options.

† Fully automatable on QIAcube Connect. See www.qiagen.com/qiacubeprotocols for protocols.

‡ Other kit sizes are available; see www.qiagen.com.

§ Wash buffers are labeled with bar codes, and expiration date is stated on the Q-card in the kit.

For up-to-date licensing information and product-specific disclaimers, see the respective QIAGEN kit handbook or user manual. QIAGEN kit handbooks and user manuals are available at www.qiagen.com or can be requested from QIAGEN Technical Services or your local distributor.

Document Revision History

Date	Changes
June 2012	Removal of risk and safety codes and statements. General update into revised template.
December 2014	Changes to comply with GHS regulation, throughout the document.
March 2018	Update into Sample to Insight branding. Change to step 3 of the spin protocol (page 28) and step 3 of the vacuum protocol (page 32), to remove an outdated study reference.
January 2020	Updated text, ordering information and intended use for QIAcube Connect.

Limited License Agreement for QIAamp Viral RNA Mini Kit

Use of this product signifies the agreement of any purchaser or user of the product to the following terms:

1. The product may be used solely in accordance with the protocols provided with the product and this handbook and for use with components contained in the kit only. QIAGEN grants no license under any of its intellectual property to use or incorporate the enclosed components of this kit with any components not included within this kit except as described in the protocols provided with the product, this handbook, and additional protocols available at www.qiagen.com. Some of these additional protocols have been provided by QIAGEN users for QIAGEN users. These protocols have not been thoroughly tested or optimized by QIAGEN. QIAGEN neither guarantees them nor warrants that they do not infringe the rights of third-parties.
2. Other than expressly stated licenses, QIAGEN makes no warranty that this kit and/or its use(s) do not infringe the rights of third-parties.
3. This kit and its components are licensed for one-time use and may not be reused, refurbished, or resold.
4. QIAGEN specifically disclaims any other licenses, expressed or implied other than those expressly stated.
5. The purchaser and user of the kit agree not to take or permit anyone else to take any steps that could lead to or facilitate any acts prohibited above. QIAGEN may enforce the prohibitions of this Limited License Agreement in any Court, and shall recover all its investigative and Court costs, including attorney fees, in any action to enforce this Limited License Agreement or any of its intellectual property rights relating to the kit and/or its components.

For updated license terms, see www.qiagen.com.

Trademarks: QIAGEN®, Sample to Insight®, QIAamp®, QIAcube®, BioRobot®, EZ1®, MagAttract®, MinELute®, UltraSens® (QIAGEN Group); Centricon®, UltraFree® (Merck KGaA); Corex® (Corning, Inc.); Tween® (ICI Americas Inc.).

HB-0354-005 © 2020 QIAGEN, all rights reserved.

Notes

Notes

Notes

Ordering www.qiagen.com/shop | Technical Support support.qiagen.com | Website www.qiagen.com